

# Under Cutter



Sizes:

Ø25mm  
to  
Ø50mm



# T-Slot Cutter



Sizes:

Ø25mm  
to  
Ø50mm



# Chamfer Cutter



Sizes:

Ø12mm to Ø28mm



# Under Cutter

**METRIC**

## DUM Type

### DUM-6R

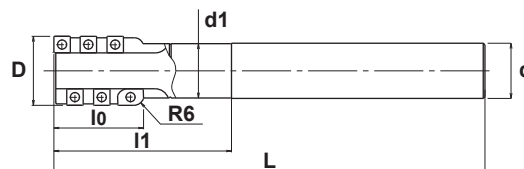

### DUM-MT

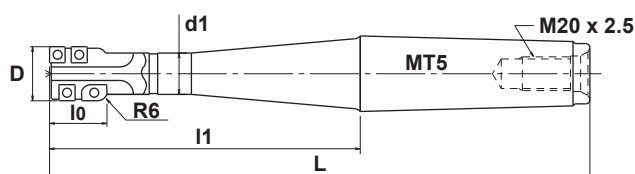

### DUM-W2R / DUM-W6R

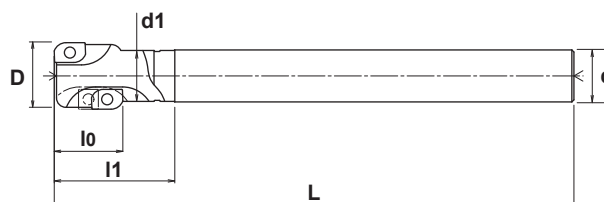

## Specifications

CATALOG NUMBER	STK	DIMENSIONS						INSERTS			PARTS	
		D	L	d1	l0	l1	d	Top	Bottom	Side	Screw	Wrench
DUM-25023S20-W2R	•	25	250	19.3	23.5	53.5	20	ZPMT13T320R (1)	ZDMT13T320L (1)	-	DSW-307	A-10
DUM-32034S25-6R	•	32	250	24.5	34	83	25	-	APGW150360L (1)	SPGA090304 (or SPMA..) (3)	DSW-4085	A-15T
DUM-32050S25-6R*	•	32	250	-	50	-	25	-	APGW150360L (1)	SPGA090304 (or SPMA..) (5)	DSW-4085	A-15T
DUM-320184T-MT5	•	32	320	24.5	34	184	MT5	-	APGW150360L (1)	SPGA090304 (or SPMA..) (3)	DSW-4085	A-15T
DUM-32033S25-W6R	•	32	250	24.5	33	58	25	APGW150360R (1)	APGW150360L (1)	SPGA090304 (or SPMA..) (1)	DSW-4085	A-15T
DUM-36038S32-6R	•	36	250	31	38	89	32	-	APGW150360L (1)	SPGA090304 (or SPMA..) (3)	DSW-4085	A-15T
DUM-36050S32-6R	•	36	250	31	50	101	32	-	APGW150360L (1)	SPGA090304 (or SPMA..) (5)	DSW-4085	A-15T
DUM-40040S32-6R	•	40	250	31.5	40	91	32	-	APGW150360L (2)	SPGA090304 (or SPMA..) (8)	DSW-4085	A-15T
DUM-40052S32-6R	•	40	250	31.5	52	103	32	-	APGW150360L (2)	SPGA090304 (or SPMA..) (10)	DSW-4085	A-15T
DUM-50020S42-6R	•	50	250	41	20	70	42	-	APGW150360L (2)	SPGA090304 (or SPMA..) (2)	DSW-4085	A-15T
DUM-50036S42-6R	•	50	250	40	36	87	42	-	APGW150360L (2)	SPGA090304 (or SPMA..) (6)	DSW-4085	A-15T
DUM-50050S42-6R	•	50	250	40	50	107	42	-	APGW150360L (2)	SPGA090304 (or SPMA..) (10)	DSW-4085	A-15T
DUM-50055S42-W6R	•	50	250	41	55.7	90	42	APGW150360R (2)	APGW150360L (2)	SPGA090304 (or SPMA..) (8)	DSW-4085	A-15T

\*Carbide Shank

Note: All cutters are supplied without inserts.

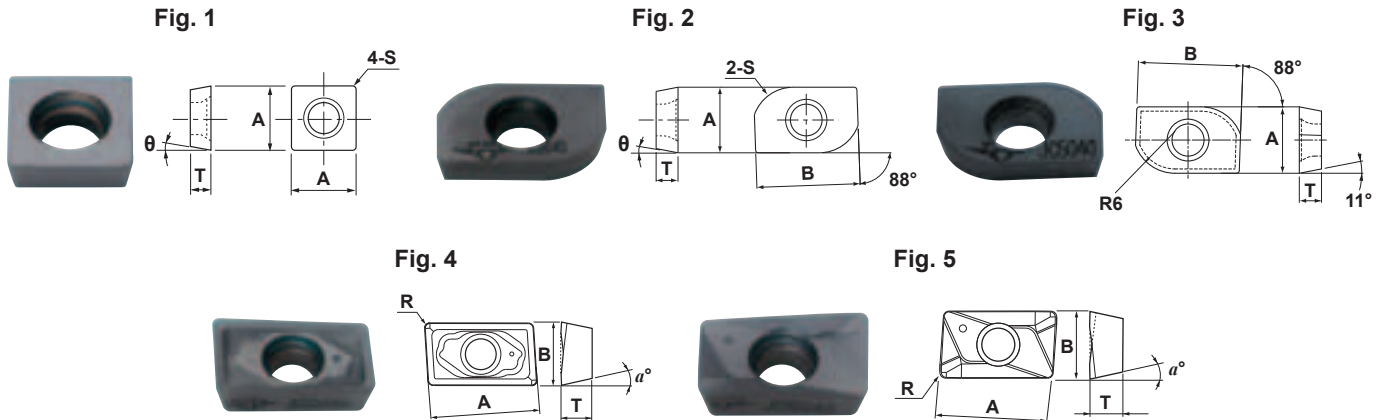
**METRIC**
**Under Cutter**
**Inserts**

**Specifications**

CATALOG NUMBER	DIMENSIONS					FIG.	COATED	
	A	B	T	R	$\alpha$		JC5015	JC5040
SPGA090304	9.525	9.525	3.18	.4	11°	1		•
SPMA090304	9.525	9.525	3.18	.4	11°	1	•	
APGW150360L	9.525	15	3.18	6	11°	2	•	•
APGW150360R	9.525	15	3.18	6	11°	3		•
ZDMT13T320L	12.9	7.938	3.97	2	15°	4	•	•
ZPMT13T320R	13.3	7.938	3.97	2	11°	5	•	•

**Recommended Cutting Conditions for Under Cutter**

TOOL DIAMETER ØD (mm)	WORK MATERIAL (Material No.)	CAST IRON (GG, GGG)		TOOL & DIE STEEL (1.2379)	
	D.O.C. Cutting Condition	Ap=1D, Ae=1mm	Ap=1D, Ae=2mm	Ap=1D, Ae=1mm	Ap=1D, Ae=2mm
25	N (min <sup>-1</sup> )	1,000	-	900	-
	Vf (mm/min)	350	-	270	-
32	N (min <sup>-1</sup> )	800	650	600	-
	Vf (mm/min)	300	170	170	-
36	N (min <sup>-1</sup> )	700	570	620	530
	Vf (mm/min)	280	150	190	110
40	N (min <sup>-1</sup> )	800	640	720	560
	Vf (mm/min)	450	290	350	200
50	N (min <sup>-1</sup> )	700	570	640	510
	Vf (mm/min)	420	280	350	220

# T-Slot Cutter

**METRIC**

## TSC Type

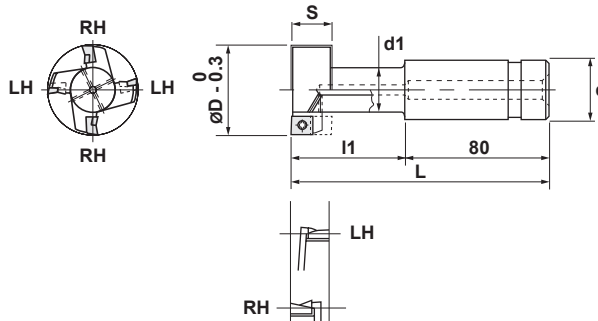

## Specifications

CATALOG NUMBER	STK	Nominal T-Slot Dimension JIS B0952	DIMENSIONS						INSERTS	Q	PARTS	
			D	L	S	l1	d	d1			Screw	Wrench
TSC2-2511S25	■	14	25	114	11	34	25	12	TSB25R (1) TSB25L (1)	2	ESW-307	A-08
TSC2-3214S32	■	18	32	122	14	42	32	15	TSB32R (1) TSB32L (1)	2	ESW-408	A-15
TSC2-4018S32	■	22	40	132	18	52	32	19	TSB40R (1) TSB40L (1)	2	ESW-410	A-15
TSC4-5022S32	■	28	50	144	22	64	32	25	TSB50R (2) TSB50L (2)	4	ESW-410	A-15

Note: All cutters are supplied without inserts.

## INSERTS

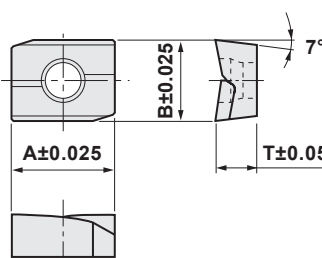
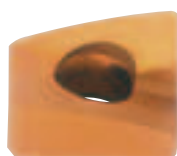

## Specifications

CATALOG NUMBER		DIMENSIONS			COATED	UNCOATED
R.H.	L.H.	A	B	T	JC3552	KT9
TSB25R	TSB25L	8	8	3.97	■	■
TSB32R	TSB32L	10	10	4.76	■	■
TSB40R	TSB40L	12	10	6.35	■	■
TSB50R	TSB50L	12	10	6.35	■	■

## Recommended Cutting Data

WORK MATERIAL	INSERT GRADE	Cutting Speed (mm/min)	Feed Rate (mm/th)
Steel	JC3552	40 - 70	0.05 - 0.2
Cast Iron	KT9	40 - 80	0.05 - 0.3

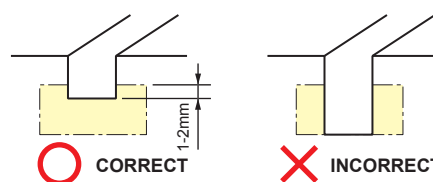

**METRIC**

# T-Slot Cutter

## S-TSC Type

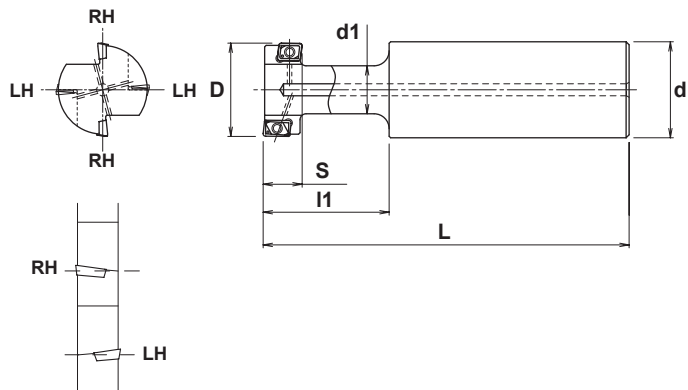

## Specifications

CATALOG NUMBER	STK	Nominal T-Slot Dimension JIS B0952	DIMENSIONS						INSERTS	Q	PARTS	
			D	L	S	l1	d	d1			Screw	Wrench
S-TSC4-3113S32	■	18	31	122	13	42	32	16	ZPMT09T208R (2) ZDMT08T208L (2)	4	TSW-2250	A-07SD
S-TSC4-3817S32	■	22	38	132	17	52	32	20	ZCMT100308R (2) ZDMT100308L (2)	4	ESW-206	A-08SD
S-TSC4-4318S42	■	24	43	166	18	56	42	22	ZCMT100308R (2) ZDMT100308L (2)	4	ESW-206	A-08SD
S-TSC4-4721S42	■	28	47	174	21	64	42	26	ZPMT13T308R (2) ZDMT13T308L (2)	4	DSW-307	A-10SD

Note: All cutters are supplied without inserts.

## INSERTS

Fig. 1 LH

Fig. 2 RH

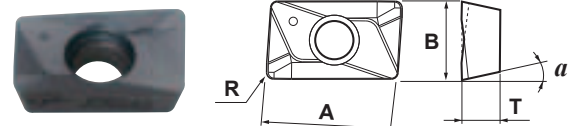
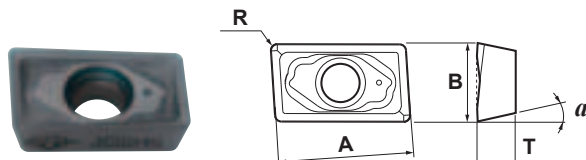

## Specifications

CATALOG NUMBER	DIMENSIONS					FIG.	COATED	
	A	B	T	R	a		JC5015	JC5040
ZDMT08T208L	7.9	6	2.78	0.8	15°	1	•	•
ZPMT09T208R	9	5.4	2.78	0.8	11°	2	•	•
ZDMT100308L	10.4	6.35	3.4	0.8	15°	1	•	•
ZCMT100308R	10.4	6.35	3.4	0.8	7°	2	•	•
ZDMT13T308L	12.9	7.938	3.97	0.8	15°	1	•	•
ZPMT13T308R	13.3	7.938	3.97	0.8	11°	2	•	•

## Recommended Cutting Data

WORK MATERIAL	HARDNESS HB	INSERT GRADE	CUTTING SPEED (mm/min)	FEED RATE (mm/rev)
Low Carbon Steel	180-280	JC5040	40-70	0.4-0.7
High Carbon Steel	180-280	JC5040	40-70	0.4-0.7
Gray Cast Iron	200-250	JC5015	60-100	0.5-0.8
Ductile Cast Iron	180-250	JC5015	40-70	0.3-0.6

# Chamfer Cutter

**METRIC**
**CMTPR type - 45 degree**

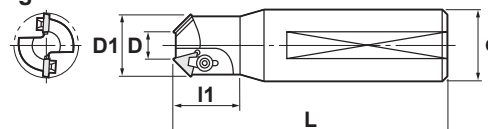
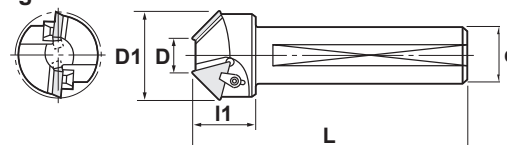
**Fig. 1**

**Fig. 2**

## Specifications

CATALOG NUMBER	STK	DIMENSIONS						INSERT	Q	PARTS		
		D	D1	L	I1	d	FIG.			Screw	Wrench	Clamp/Clamp Set
CMTPR122S32	■	12	25.8	120	30	32	1	TPMN110304 TPGN110304	2	-	LW-025	DCM-1
CMTPR182S32	■	18	37.9	120	40	32	2	TPMN160308 TPGN160308	2	-	LW-030	DCM-5
CMTPR282S32	■	28	55.6	120	40	32	2	TPMN220408 TPGN220408	2	SLS-3	LW-040	DCM-2

Note: All cutters are supplied without inserts.

## Inserts

	CATALOG NUMBER	DIMENSIONS			COATED			UNCOATED		
		A	T	R	JC5040	JC5030	JC730U	NIT	UMS	KT9
	TPMN110304	6.35	3.18	0.4				•		•
TPMN160308(T)	9.525	3.18	0.8	•	•	•			•	
TPMN220408(T)	12.70	4.76	0.8	•	•	■	■		•	
TPGN110304	6.35	3.18	0.4				■		■	
TPGN160308	9.525	3.18	0.8						■	
TPGN220408	12.70	4.76	0.8						■	

## Recommended Cutting Data

WORK MATERIAL	INSERT GRADE	SPEED (m/min)	FEED RATE (mm/tooth)
Carbon Steel	JC5040, JC5030, NIT	100-150	0.1 - 0.2
Alloy Steel	JC5040, JC5030, NIT	60-120	0.1 - 0.3
Cast Iron	KT9	80-100	0.1 - 0.2