

Referans Nr.	a	m	h		s	e1	e2	d	sw	L	b	e3	c	(g)
			min	max										
1120-014 DT	14	M12	36	86	12-66	136	71.5	M14	8	104	38	38	13	2540
1120-016 DT	16	M12	36	86	12-66	136	71.5	M14	8	104	38	38	13	2540
1120-018 DT	18	M12	36	86	12-66	136	71.5	M14	8	104	38	38	13	2540
1130-014 DT	14	M12	45	105	15-83	158	83	M18	10	130	48	45	17.5	4750
1130-016 DT	16	M12	45	105	15-83	158	83	M18	10	130	48	45	17.5	4775
1130-018 DT	18	M12	45	105	15-83	158	83	M18	10	130	48	45	17.5	4805
1130-020 DT	20	M12	45	105	15-83	158	83	M18	10	130	48	45	17.5	4855
1130-022 DT	22	M12	45	105	15-83	158	83	M18	10	130	48	45	17.5	4905

Ürün Nr. 1120:Alt Destekli

- M12 İmbus civata DIN 508 T-Pabuçla kullanılır.
- Parça yükseklik sıkma aralığı 36-86mm
- Sıkma kuvveti 1600kgf

Product Nr. 1120:Bottom Supported

- M12 imbus bolt is used with DIN 508 T-Nut.
- Height clamping gap of the piece is 36-86mm
- Clamping Force is 1600kgf

Ürün Nr. 1130:Alt Destekli

- M12 İmbus civata DIN 508 T-Pabuçla kullanılır.
- Parça yükseklik sıkma aralığı 45-105mm
- Sıkma kuvveti 2000kgf

Product Nr. 1130:Bottom Supported

- M12 imbus bolt is used with DIN 508 T-Nut.
- Height clamping gap of the piece is 45-105mm
- Clamping Force is 2000kgf

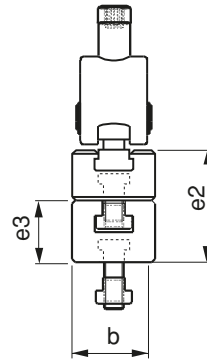
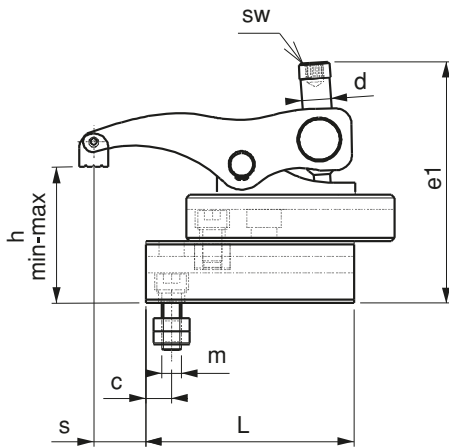

UYGULAMA;

- 1- Alt desteği iş parçasına uygun şekle getir sabitle
- 2- K.K.S.P destekler artırılarak istenilen mesafeye ulaşılır
- 3- K.K.S.P imbus civata ile T-Pabuca karşılık T-Kanala tak istenilen pozisyona getir.
- 4- Pabuç imbus civatasıyla iş parçasını sabitle

APPLICATION

- 1- Bottom support is brought to suitable form with the work piece and then it is fixed.
- 2- Desired distance is reached by increasing K.K.S.P supports
- 3- K.K.S.P is applied in T-Slot with imbus bolt against T-Nut
- 4- Work piece is fixed with the imbus bolt of the clamp

