

Referans Nr.	D		H	H1	R	H2		L1	Uygun Civatalar Proper Cap Screws	Sıkma Kuvveti Clamping Force Kgf	 (g)
	min.	max.				min.	max.				
1487-04001	19.5	24	9	2.5	R9.5	8	2.6	9.4	M4	200	20
1487-06001	23.5	29	13	4	R11.5	11.5	5	13	M6	500	45
1487-08001	28.5	36	17	5.5	R14	15	6	19	M8	900	90

Ürün Nr. 1487 Delik İçi Bağlama

- Sertleştirilmiş
- Siyah Kaplama

Product Nr. 1487 I.D. Holding Clamps

- Hardened
- Black coated

Özellik

- Bu pabuçlar iş parçasını iç çaptan sıkma işlemi yapar.
- Kamanın konik yapısından dolayı güçlü bir bağlama yapar.
- Uzun strok özelliği ile dökülmüş deliklerde ve kaba deliklerde kullanım olanağı sağlar.

Feature

- These clamps hold the inside diameter of the workpiece.
- The wedge construction allows powerfully clamping the workpiece.
- Long clamping stroke is ideal for holding as-cast or roughly-finished holes.

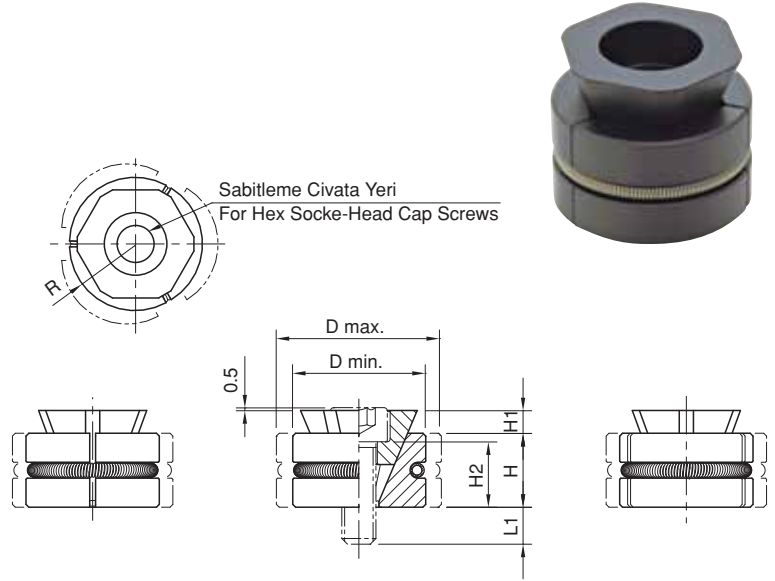

Kullanım Şekli / How To Use

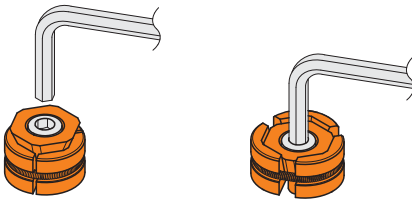

Açık Konum
Unclamping Mode

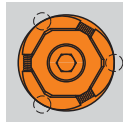

Kapalı Konum
Clamping Mode

İş parçasını sıkma anında çizgi halinde temas eder. Finitş delikler için tavsiye edilmez. Delik içinde deforme olabilir.

The clamp makes a line contact with the workpiece at the clamping mode. This contact can mar the surface of the workpiece depending on its materials, and using these clamps for accurately finished holes is not recommended.

Not

- Doğru bir merkezleme işlemi aşağıdaki görsel gibidir.

Notes

- For accurate locating, use these clamps with a locator as shown below.

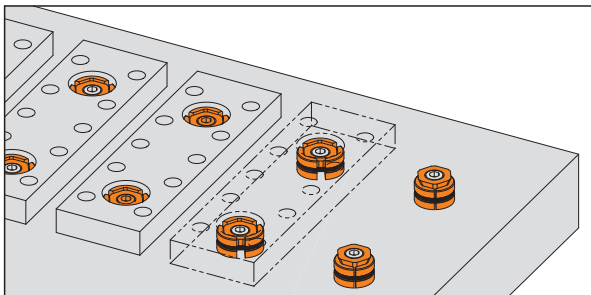
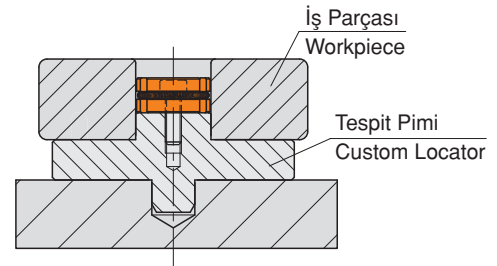

2'li bağlama uygulama örneğidir.

Example of application where two I.D. Holding Clamps are used.